

MODEL CODE	PART NUMBER	MOTOR TYPE
URUZ 12.5 VE6T1111	103111	12V DC



## STANDARD COMPLIANCE

EN14492-2 :2019, SAE J706  
 2006/42/EC - EN ISO 121000 :2010, ISO 7637-2 :2004  
 2014/30/EU – EN50498 :2010, ISO7637-2 :2011, CISPR 25: 2008

## WINCH SPECIFICATIONS

Rated Pulling Force	5670 kgf	12500 lbf
Drum Barrel Diameter	126 mm	4.96 in
Drum Width	197 mm	7.76 in
Evaluated Rope Diameter	Ø12	1/2 in
Maximum Wire Rope Diameter	Ø14	9/16 in
Minimum Wire Rope Breaking Strength	11105 kgf	24482 lbf
Recommended Wire Rope Type	6 x 29 IWRC	
Maximum Layers of Wire Rope	4	
Gear Train, Reduction	3 Stage Planetary, 358.3:1	
Mounting Bolt Size	M12 X 1.75 Class 8.8	
Mounting Bolt Torque	63-69 Nm	46-51 lbf-ft
Duty Cycle (per EN 1449-2)	3.9 m	12.8 ft
Approximate Shipping Weight	69.6 kg	153.4 lb
Brake Type	Automatic Mechanical Brake	
Sealing	IP68	
UV Rating	1200kJ/m <sup>2</sup> per ASTM G154	
Corrosion Resistance	408 hrs per ASTM B117	
Operating Temperature	-40°C to +60°C (-25.6°F to 131°F)	
Decibels	95 Db	

## PERFORMANCE BY LAYER

Drum Layer	Line Pull		Line Speed		Rope Capacity	
	kgf	lbf	mpm	fpm	m	ft
1	5670	12500	8,00	26,25	6,9	22,64
2	4928	10864	9,22	30,25	14,4	47,24
3	4357	9605	10,41	34,15	23,4	76,77
4	3905	8609	11,62	38,12	32,5	106,6

## PERFORMANCE BY LAYER

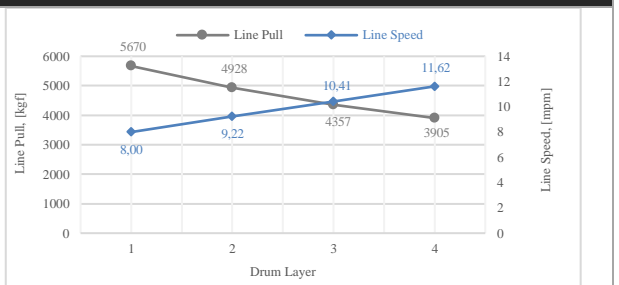

## FIRST LAYER PERFORMANCE

Line Pull	Line Speed	Current Draw	Duty Cycle
	12V	12V	12V
kgf/lbf	mpm	Amps	min/10min
0	8,00	61,10	5:00
1361 / 3000	4,25	144,20	2:50
2722 / 6000	3,05	235,60	1:55
4082 / 9000	2,39	315,60	1:00
4310 / 9500	1,88	385,90	0:45
5670 / 12500	1,80	402,40	0:35

## FIRST LAYER PERFORMANCE

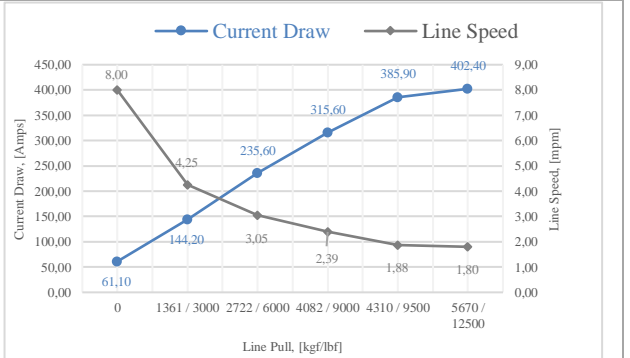

MODEL CODE	PART NUMBER	MOTOR TYPE
URUZ 12.5 VE6T1111	103111	12V DC

ELECTRICAL SYSTEM REQUIREMENTS	
Battery Voltage	12V
Minimum Battery Rating	650 CCA

### THE SET INCLUDES:

- Wire rope
- Rope hook
- Control box
- Roller guides
- Mounting screws
- Remote control

\* Order wireless remote control separately

### ELECTRICAL WIRING DIAGRAM

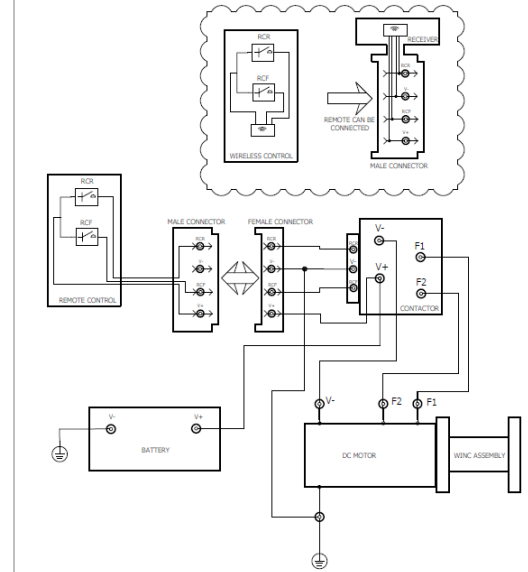

### DIMENSIONAL DRAWING

