

MODEL CODE	PART NUMBER	MOTOR TYPE
URUZ 9.5 VE5T1112	108112	24V DC



STANDARD COMPLIANCE

EN14492-2 :2019, SAE J706
 2006/42/EC - EN ISO 121000 :2010, ISO 7637-2 :2004
 2014/30/EU – EN50498 :2010, ISO7637-2 :2011, CISPR 25: 2008

WINCH SPECIFICATIONS

Rated Pulling Force	4310 kgf	9500 lbf
Drum Barrel Diameter	126 mm	4.96 in
Drum Width	197 mm	7.76 in
Evaluated Rope Diameter	Ø11.2	7/16 in
Maximum Wire Rope Diameter	Ø14	9/16 in
Minimum Wire Rope Breaking Strength	9616 kgf	21200 lbf
Recommended Wire Rope Type	6 x 29 IWRC	
Maximum Layers of Wire Rope	4	
Gear Train, Reduction	3 Stage Planetary, 284:1	
Mounting Bolt Size	M12 X 1.75 Class 8.8	
Mounting Bolt Torque	63-69 Nm	46-51 lbf-ft
Duty Cycle (per EN 1449-2)	18.7 m	61.4 ft
Approximate Shipping Weight	62.5 kg	137.8 lb
Brake Type	Automatic Mechanical Brake	
Sealing	IP68	
UV Rating	1200kJ/m ² per ASTM G154	
Corrosion Resistance	408 hrs per ASTM B117	
Operating Temperature	-40°C to +60°C (-25.6°F to 131°F)	
Decibels	95 Db	

PERFORMANCE BY LAYER

Drum Layer	Line Pull		Line Speed		Rope Capacity	
	kgf	lbf	mpm	fpm	m	ft
1	4310	9500	8,00	26,25	7,3	23,95
2	3776	8325	9,13	29,95	15,2	49,87
3	3360	7408	10,26	33,66	24,6	80,71
4	3026	6671	11,39	37,37	34,4	112,9

PERFORMANCE BY LAYER

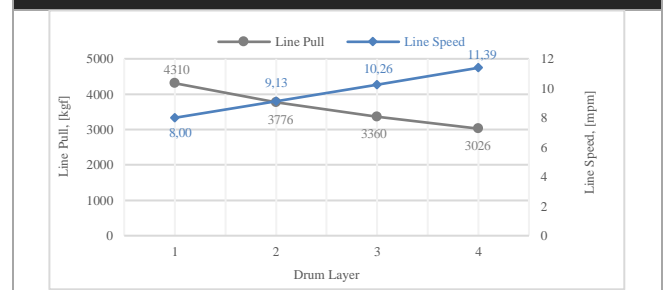

FIRST LAYER PERFORMANCE

Line Pull	Line Speed	Current Draw	Duty Cycle
kgf/lbf	mpm	Amps	min/10min
0	8,00	50,50	5:00
1361 / 3000	4,02	120,60	1:50
2722 / 6000	2,50	178,30	0:45
4082 / 9000	2,02	219,80	0:30
4310 / 9500	1,86	235,60	0:20

FIRST LAYER PERFORMANCE

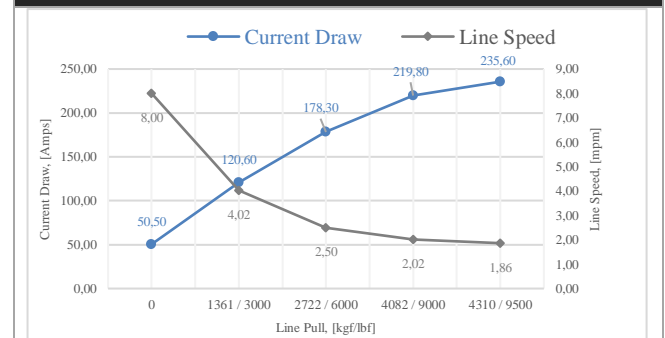

MODEL CODE	PART NUMBER	MOTOR TYPE
URUZ 9.5 VE5T1112	108112	24V DC

ELECTRICAL SYSTEM REQUIREMENTS

Battery Voltage	24V
Minimum Battery Rating	650 CCA

THE SET INCLUDES:

- Wire rope
- Rope hook
- Control box
- Roller guides
- Mounting screws
- Remote control

* Order wireless remote control separately

ELECTRICAL WIRING DIAGRAM

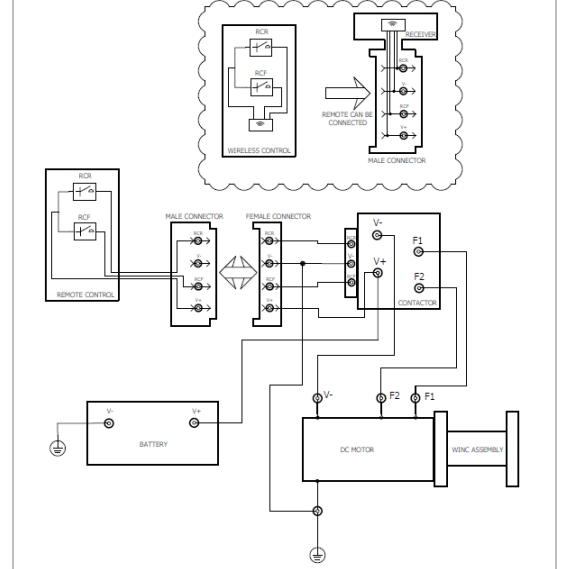

DIMENSIONAL DRAWING

