

MODEL CODE	PART NUMBER	MOTOR TYPE
BASAT HYD 9 VH4T2111	112211	HYDRAULIC 50 cc

STANDARD COMPLIANCE
EN14492-2 :2019*, SAE J706
2006/42/EC - EN ISO 121000 :2010, ISO 7637-2 :2004
2014/30/EU – EN50498 :2010, ISO7637-2 :2011, CISPR 25: 2008
*Conforms with exceptions



WINCH SPECIFICATIONS		
Rated Pulling Force	4082 kgf	9000 lbf
Drum Barrel Diameter	105 mm	4.13 in
Drum Width	252.7 mm	9.95 in
Evaluated Rope Diameter	10 mm	3/8 in
Maximum Wire Rope Diameter	13 mm	1/2 in
Minimum Wire Rope Breaking Strength	7668 kgf	16905 lbf
Recommended Wire Rope Type	6 x 29 IWRC	
Maximum Layers of Wire Rope	4	
Gear Train, Reduction	2 Stage Planetary, 33:1	
Mounting Bolt Size	M12 X 1.75 Class 8.8	
Mounting Bolt Torque	63-69 Nm	46-51 lbf-ft
Duty Cycle (per EN 1449-2)	N/A	N/A
Approximate Shipping Weight	50.4 kg	111.12 lb
Brake Type	Automatic Mechanical Brake	
Sealing	IP68	
UV Rating	1200kJ/m ² per ASTM G154	
Corrosion Resistance	408 hrs per ASTM B117	
Operating Temperature	-40°C to +60°C (-25.6°F to 131°F)	
Decibels	95 Db	

PERFORMANCE BY LAYER				
Drum Layer	Line Pull kgf / lbf	Line Speed mpm / fpm		Rope Capacity m / ft
		10gpm	13gpm	
1	4082 / 9000	8,6 / 28,2	10,7 / 35,1	6,8 / 22,3
2	3547 / 7820	9,9 / 32,5	12,3 / 40,3	14,3 / 46,9
3	3137 / 6916	11,2 / 36,7	13,9 / 45,6	23,2 / 76,1
4	2811 / 6197	12,5 / 41	15,5 / 50,8	32,6 / 106,9

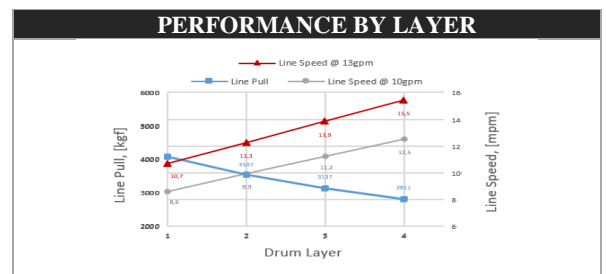

FIRST LAYER PERFORMANCE					
Line Pull	Line Speed mpm / fpm		Pressure		Duty Cycle
	10gpm	13gpm	10gpm	13gpm	
kgf / lbf	mpm / fpm		bar / psi		min/10min
0	8,6 / 28,2	10,7 / 35,1	19 / 275,6	30 / 435	N/A
1361 / 3000	8,4 / 27,5	10,5 / 34,4	45 / 652,7	52 / 754,2	N/A
2722 / 6000	8,2 / 26,9	10,3 / 33,8	90 / 1305	98 / 1421,4	N/A
4082 / 9000	8 / 26,2	10,1 / 33,1	130 / 1885	135 / 1958	N/A

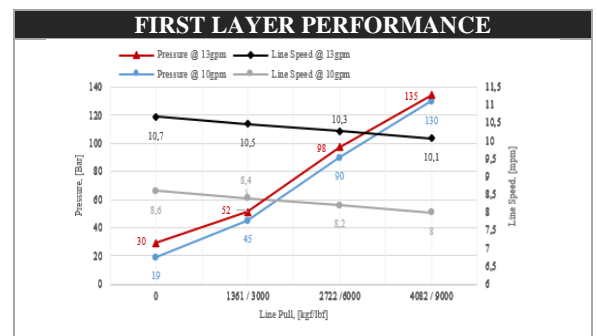

MODEL CODE	PART NUMBER	MOTOR TYPE
BASAT HYD 9 VH4T2111	112211	HYDRAULIC 50 cc

HYDRAULIC SYSTEM REQUIREMENTS	
Maximum System Pressure	172 bar / 2500 psi
Maximum Rated Input Flow	50 lpm / 13 gpm

DRUM CAPACITY BY LAYER, m / ft													
		DRUM LENGTH											
		6.5"			8"			10"			12.5"		
Layer	Rope Dia	10 mm	11 mm	13 mm	10 mm	11 mm	13 mm	10 mm	11 mm	13 mm	10 mm	11 mm	13 mm
		3/8 in	7/16 in	1/2 in	3/8 in	7/16 in	1/2 in	3/8 in	7/16 in	1/2 in	3/8 in	7/16 in	1/2 in
1		5.2	5.1	4.40	6.8	6.2	5.50	9.9	7.6	6.6	10.8	9.8	8.5
		17.1	16.7	14.4	22.3	20.3	18.0	32.5	24.9	21.6	35.4	32.2	27.8
2		10.9	10.6	9.20	14.3	13.0	11.6	16.8	16.5	14.5	22.8	21.1	18.6
		35.8	34.8	30.2	46.9	42.7	38.1	55.1	54.1	47.5	74.8	62.2	61.0
3		17.7	16.9	15.3	23.2	21.2	19.2	18.6	26.2	23.2	36.9	33.7	29.8
		58.1	55.5	50.2	76.1	69.6	63.0	61.0	86.0	76.1	121.1	110.6	97.7
4		24.6	23.5	21.4	32.6	30.4	27.3	39.2	36.7	32.1	51.4	48.4	40.8
		80.7	77.1	70.2	107.0	99.7	89.5	128.6	120.4	105.3	168.6	158.8	133.9

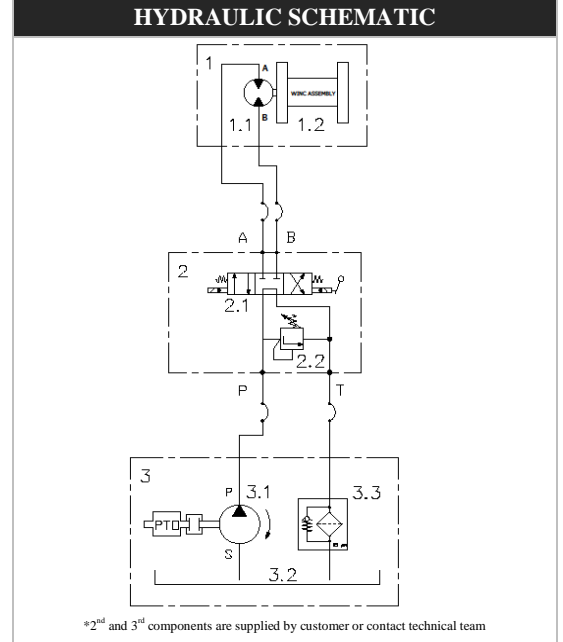

DIMENSIONAL DRAWING

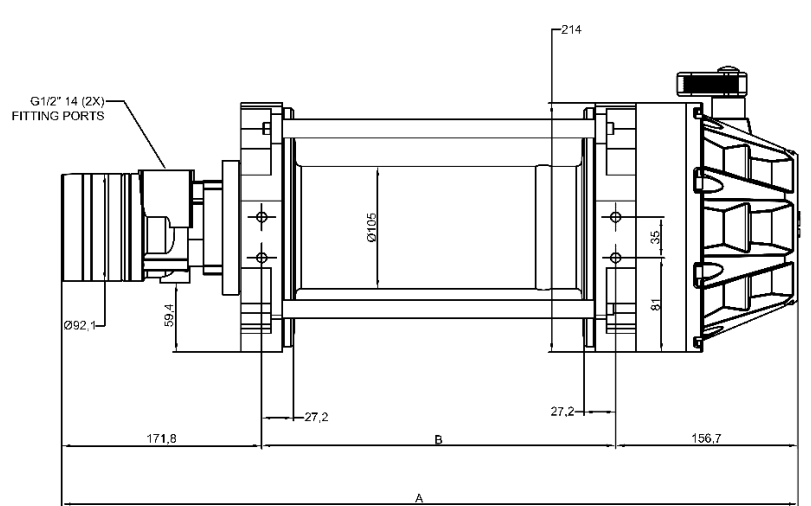
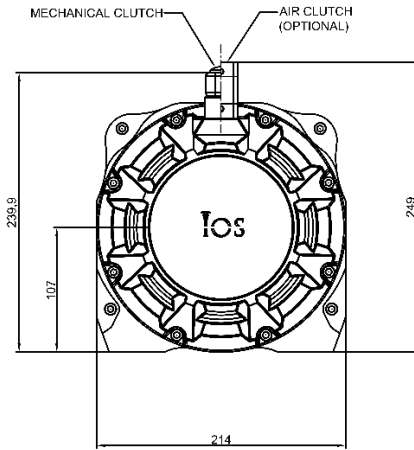

DRUM SIZE	UNITS	A	B
6.5"	mm	544.5	216.0
	in	21.4	8.5
8"	mm	582.5	254.0
	in	22.9	10.0
10"	mm	633.0	304.5
	in	24.9	12.0
12.5"	mm	696.5	368.0
	in	27.4	14.5

