

MODEL CODE	PART NUMBER	MOTOR TYPE
URUZ HYD AIR 16.5 VH8T1112	119112	HYDRAULIC 50 cc



**EN 14492-1
COMPLIANT**

STANDARD COMPLIANCE
EN14492-2 :2019, SAE J706
2006/42/EC - EN ISO 121000 :2010, ISO 7637-2 :2004
2014/30/EU – EN50498 :2010, ISO7637-2 :2011, CISPR 25: 2008

WINCH SPECIFICATIONS		
Rated Pulling Force	7484 kgf	16500 lbf
Drum Barrel Diameter	126 mm	4.96 in
Drum Width	197 mm	7.76 in
Evaluated Rope Diameter	Ø14	9/16 in
Maximum Wire Rope Diameter	Ø14	9/16 in
Minimum Wire Rope Breaking Strength	15000 kgf	33069 lbf
Recommended Wire Rope Type	6 x 29 IWRC	
Maximum Layers of Wire Rope	4	
Gear Train, Reduction	2 Stage Planetary, 51.5:1	
Mounting Bolt Size	M12 X 1.75 Class 8.8	
Mounting Bolt Torque	63-69 Nm	46-51 lbf-ft
Duty Cycle (per EN 1449-2)	N/A	N/A
Approximate Shipping Weight	62.5 kg	137.8 lb
Brake Type	Automatic Mechanical Brake	
Sealing	IP68	
UV Rating	1200kJ/m ² per ASTM G154	
Corrosion Resistance	408 hrs per ASTM B117	
Operating Temperature	-40°C to +60°C (-25.6°F to 131°F)	
Decibels	95 Db	

PERFORMANCE BY LAYER				
Drum Layer	Line Pull kgf / lbf	Line Speed mpm / fpm		Rope Capacity m / ft
		10gpm	15gpm	
1	7484 / 16500	7,4 / 24,3	10 / 32,8	6,2 / 20,34
2	6380 / 14063	8,7 / 28,5	11,7 / 38,4	12,9 / 42,32
3	5559 / 12253	10 / 32,8	13,5 / 44,3	21,2 / 69,55

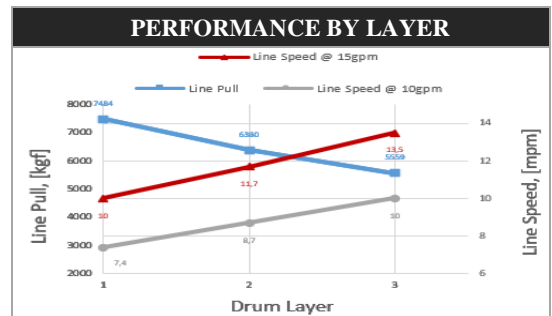

FIRST LAYER PERFORMANCE					
Line Pull	Line Speed		Pressure		Duty Cycle
	10gpm	15gpm	10gpm	15gpm	
kgf / lbf	mpm / fpm		bar / psi		min/10min
0	7,4 / 24,3	10 / 32,8	15 / 217,6	27 / 391,6	N/A
1361 / 3000	7,2 / 23,6	9,5 / 31,2	45 / 652,7	58 / 841,2	N/A
2722 / 6000	6,9 / 22,6	9,2 / 30,2	85 / 1232,8	96 / 1392,4	N/A
4082 / 9000	6,8 / 22,3	9,1 / 29,8	110 / 1595,4	128 / 1856,5	N/A
4310 / 12000	6,7 / 22	9 / 29,5	140 / 2030,5	150 / 2175,6	N/A
6804 / 15000	6,6 / 21,6	8,9 / 29,2	150 / 2175,6	160 / 2320,6	N/A
7484 / 16500	6,5 / 21,3	8,8 / 28,9	172 / 2494,6	178 / 2581,7	N/A

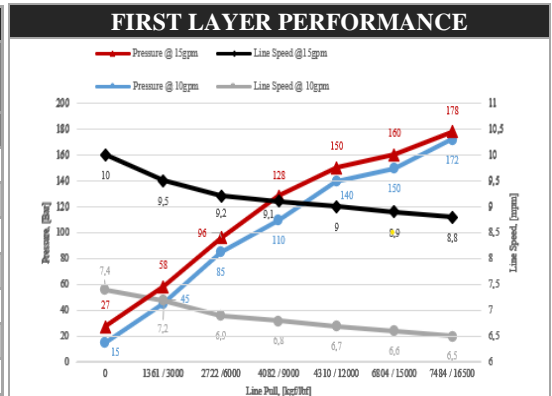

MODEL CODE	PART NUMBER	MOTOR TYPE
URUZ HYD AIR 16.5 VH8T1112	119112	HYDRAULIC 50 cc

HYDRAULIC SYSTEM REQUIREMENTS	
Maximum System Pressure	172 bar / 2500 psi
Maximum Rated Input Flow	60 lpm / 15 gpm

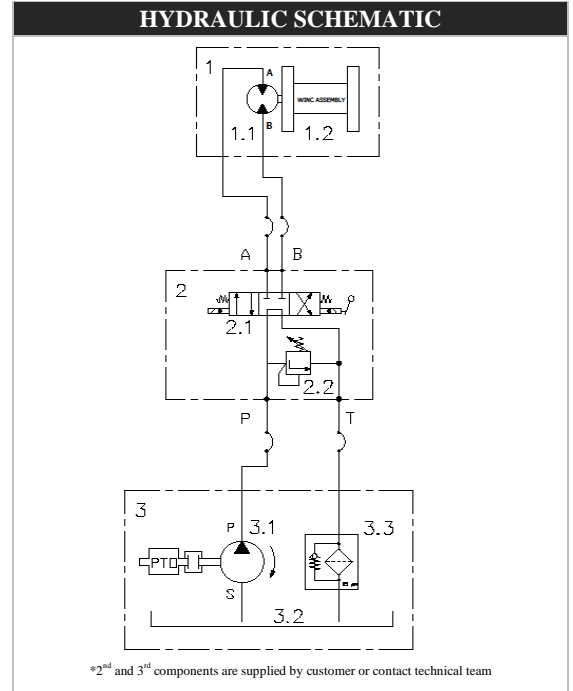

DIMENSIONAL DRAWING

